

## Snapshot

The **FXAF-12** is a single housing water treatment system with a drop-in 2.5" x 20" cartridge that takes out dirt, rust and other particulates down to 5 micron. The system can be used as a point-of-use sediment reduction filter; or it can be applied prior to a primary filtration system to provide additional prefiltration to protect against premature plugging due to excessive dirt and sediment levels found in some water supplies.

## System Benefits

- Extends the life and capacity of a down-line filtration system.
- PolyTrix® gradient-density depth filtration reduces dirt, rust, and other debris as small as 5 micron to assure clean, clear water and protect solenoids, valves and other fittings against wear and plugging.
- Protecting down-line filtration systems against premature plugging reduces filter change frequency and associated cost.
- Sturdy mounting bracket and full-flow inlet shut-off valve makes installation simple.
- Built-in inlet shut-off and depressurization valves make changing the filter quick and simple.
- Generates less waste, only the drop-in cartridge is replaced. No discarding of metal or plastic quick-change filters.
- Built-in pressure gauge allows visual monitoring of operating pressure.

ITEM #: \_\_\_\_\_ QTY: \_\_\_\_\_  
JOB NAME/NUMBER \_\_\_\_\_



## Application

ALL EQUIPMENT APPLICATIONS - *When excessive sediment is a problem.*

EXISTING FILTRATION SYSTEMS - *Provides added prefiltration to extend filter life.*

## Installation Tips

- Feed-water connection to system should be COLD only.
- Do not exceed system specifications for temperature and pressure.
- Allow 3" clearance below system for filter housing removal and cartridge replacement.
- Detailed installation, operation & maintenance manual is included with each system.
- No activation procedure or flushing is required for system to perform as specified.

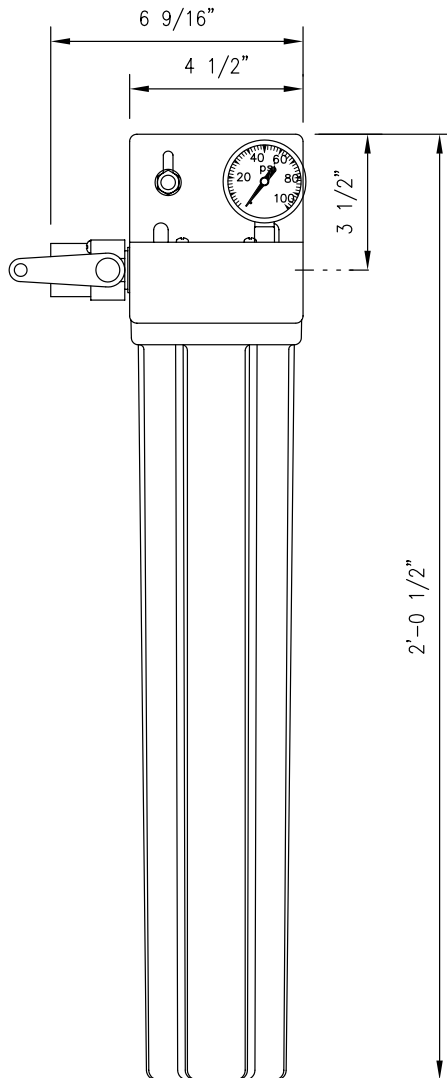

## ► Specifications

System	
Dimensions Height x Width X Depth, inches	24 1/2" x 6 9/16" x 5 1/8"
Connection - Inlet & Outlet	1/2" NPT female
Operating Pressure Range	10-125 psi (0.7 -8.6 bar)
Inlet Water Temperature Range	35° -100° F (2° -38° C)
Shipping Weight	10 lbs.
Performance	
Chlorine, Taste and Odor Reduction Capacity	N/A
Service Flow Rate	5 gpm (19 lpm)
Sediment Reduction	5 micron (nominal)
Scale & Corrosion Inhibitor	N/A

## ► Replacement Cartridge(s)

Model	Part Number	Qty
S5-20	252-10120	1

It is recommended that filters be changed every six months, when capacity is reached or when effluent pressure or flow becomes inadequate.

This product is for commercial use only and must be installed and maintained according to manufacturers guidelines.

Do not use on water that is microbiologically unsafe or of unknown quality without adequate disinfection before or after the system.

## ► Warranty

Systems have a 3 year warranty against defects in material and workmanship. For complete warranty information contact OptiPure customer service or go to [www.optipurewater.com](http://www.optipurewater.com).

Dealer/Distributor Info:

**OptiPure, Mfg. by Procam Controls, Inc.**  
2605 Technology Dr., Bldg 300  
Plano, TX 75074  
p: 972.881.9797; f: 972.422.6262  
[www.optipurewater.com](http://www.optipurewater.com)