

## Snapshot

The **FXI-22** is a two housing water treatment system with drop-in 20" cartridges that reduces sediment down to 0.5 micron and reduces chlorine, taste & odor at a flow rate of 3.0 gpm for 30,000 gallons. The system includes IsoNet<sup>®</sup>, OptiPure's patented scale inhibiting technology, which delivers consistent protection against the precipitation and accumulation of scale and provides a protective barrier to help guard against corrosion.

## System Benefits

- IsoNet<sup>®</sup> - OptiPure's patented scale inhibiting technology helps protect equipment against scale and corrosion for the rated capacity of the system.
- Reduces maintenance frequency and cost, and extends equipment life.
- Gradient-density depth filtration reduces dirt, rust, and other debris as small as 1/2 micron to assure clean, clear water and protect solenoids, valves and other fittings against wear and plugging.
- Five micron Polytrix prefilter provides added protection against excessive sediment found in some water supplies.
- High capacity activated carbon filtration makes water taste great and protects equipment against corrosive chlorine.
- Improves equipment operating efficiency.
- Sturdy mounting bracket and full-flow inlet shut-off valve makes installation simple.
- Built-in pressure gauges allows visual monitoring of differential and operating pressure.
- Inlet shut-off and depressurization valves make changing the filter quick and simple.
- Generates less waste, only the drop-in filters are replaced. No discarding of metal or plastic quick-change filters.
- Replacement cartridge cost per gallon is much less than proprietary quick-change filters.
- NSF Certified under Standard 42.

ITEM #: \_\_\_\_\_ QTY: \_\_\_\_\_  
JOB NAME/NUMBER \_\_\_\_\_



## Application

ICE - Cubers up to 1,500 lbs. and flakers up to 2,000 lbs.  
Includes prefilter for water supplies with high turbidity levels.

COFFEE - Multiple brewer up to 3 gpm.

STEAM & COMBI OVENS - High volume

## Installation Tips

- Feed-water connection to system should be COLD only.
- Do not exceed system specifications for temperature and pressure.
- Allow 3" clearance below system for filter housing removal and cartridge replacement.
- Connect filtered water line to ice and steam production connections only. Do not use for condenser water.
- Detailed installation, operation & maintenance manual is included with each system.
- No activation procedure or flushing is required for system to perform as specified.

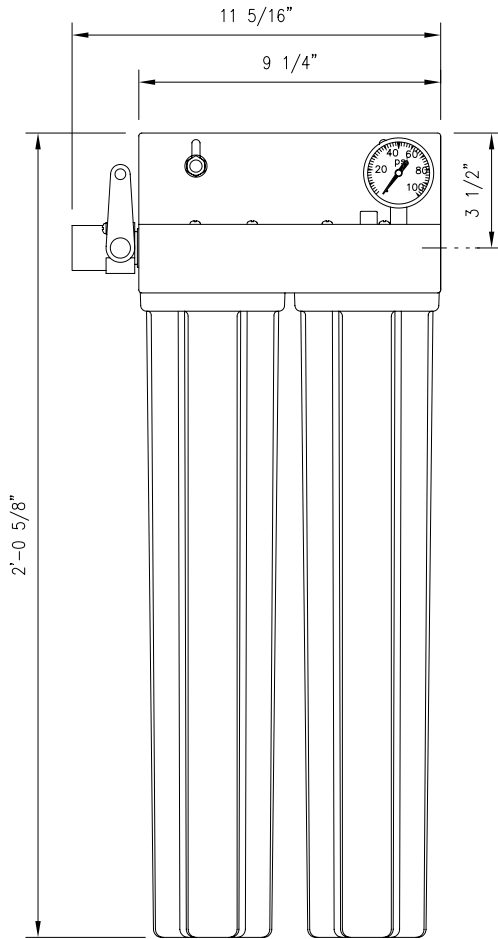

Model FXI-22 is tested and certified by NSF International against NSF/ANSI Standard 42 for the reduction of:  
Standard 42: Aesthetic Effects,  
Chlorine Reduction  
Taste and Odor Reduction  
Nominal Particulate Reduction, Class 1

Dealer/Distributor Info:

## ► Specifications

System	
Dimensions Height x Width X Depth, inches	24 5/8" x 11 5/16" x 5 3/4"
Connection - Inlet & Outlet	1/2" NPT female
Operating Pressure Range	10-125 psi (0.7 -8.6 bar)
Inlet Water Temperature Range	35° -100° F (2° -38° C)
Shipping Weight	14 lbs.
Performance	
Chlorine, Taste and Odor Reduction Capacity	30,000 gals (113,400 liters)
Service Flow Rate	3.0 gpm (11.3 lpm)
Sediment Reduction	.5 micron (nominal)
Scale & Corrosion Inhibitor	IsoNet (140 grams)

Optional Flush Valve Kit - Part #: 160-52910

## ► Replacement Cartridge(s)

Model	Part Number	Qty
S5-20	252-10120	1
CTOS-20	252-20220	1

It is recommended that filters be changed every six months, when capacity is reached or when effluent pressure or flow becomes inadequate.

This product is for commercial use only and must be installed and maintained according to manufacturers guidelines.

Do not use on water that is microbiologically unsafe or of unknown quality without adequate disinfection before or after the system.

## ► Warranty

Systems have a 3 year warranty against defects in material and workmanship. For complete warranty information contact OptiPure customer service or go to [www.optipurewater.com](http://www.optipurewater.com).

**OptiPure, Mfg. by Procam Controls, Inc.**  
2605 Technology Dr., Bldg 300  
Plano, TX 75074  
p: 972.881.9797; f: 972.422.6262  
[www.optipurewater.com](http://www.optipurewater.com)