

Snapshot

The **FXWS-12B** is a single housing water treatment system with a drop-in 20" x 4 1/2" high capacity ion exchange (softening) cartridge that removes calcium and magnesium hardness minerals from water. The system also takes out dirt and sediment down to 10 micron. The system can be used as a point-of-use softening filter; or it can be applied to a specific point-of-use down-line in combination with a primary system.

System Benefits

- Takes out hardness minerals that form damaging scale (lime-scale).
- Reduces maintenance frequency and cost, and extends equipment life.
- Takes out dirt, rust and sediment down to 10 micron to protect solenoids, valves and other fittings against wear and plugging.
- Improves equipment operating efficiency.
- Heavy duty powder-coated steel mounting bracket makes installation simple.
- Built-in inlet shut-off and depressurization valves make changing the filter quick and simple.
- Only the drop-in cartridge is replaced. No discarding of metal or plastic quick-change filters.

ITEM #: _____ QTY: _____

JOB NAME/NUMBER _____



Application

ESPRESSO - *traditional, semi-auto and super-automatic machines.*

TEA BREWERS

STEAM AND COMBI OVENS - *low volume countertop ovens*

COMBINATION (Secondary Filtration) - *Removes hardness minerals from water prior to a specific point-of-use down-line in combination with a primary system.*

Installation Tips

- Feed-water connection to system should be COLD only.
- Do not exceed system specifications for temperature and pressure.
- Allow 3" clearance below system for filter housing removal and cartridge replacement.
- Connect filtered water line to steam production connections only. Do not use for condenser water.
- Detailed installation, operation & maintenance manual is included with each system.
- Flush the cartridge for two minutes prior to connecting equipment.

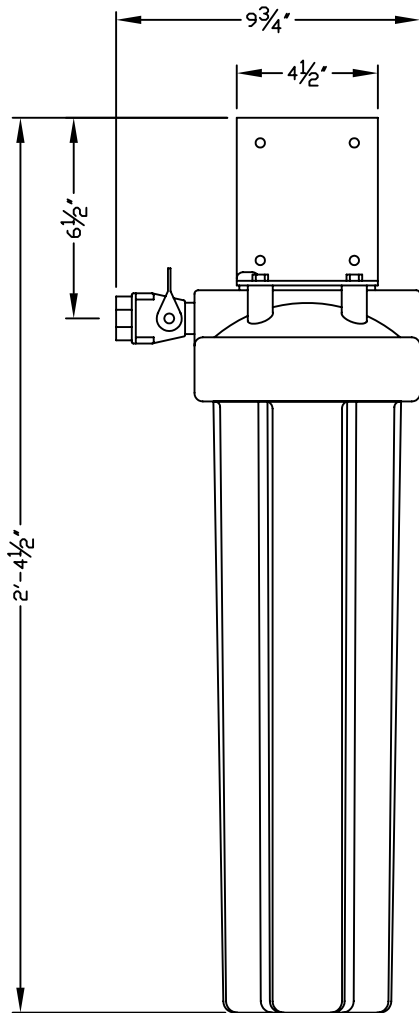

► Specifications

System	
Dimensions Height x Width X Depth, inches	28 1/2" x 13 1/2" x 8 1/2"
Connection - Inlet & Outlet	3/4" NPT female
Operating Pressure Range	10-125 psi (0.7 -8.6 bar)
Inlet Water Temperature Range	35° -100° F (2° -38° C)
Shipping Weight	22 lbs.
Performance	
Water Softening Capacity	5,200 grains
Service Flow Rate	2.0 gpm (lpm)
Sediment Reduction	10 micron (nominal)
Scale Prevention	Ion Exchange

Optional Flush Valve Kit - Part #: 160-52614

► Replacement Cartridge(s)

Model	Part Number	Qty
WS-20B	252-60040	1

It is recommended that filter be changed when softening capacity is reached or when effluent pressure or flow becomes inadequate. At a minimum change every six months.

This product is for commercial use only and must be installed and maintained according to manufacturers guidelines.

Do not use on water that is microbiologically unsafe or of unknown quality without adequate disinfection before or after the system.

► Warranty

Systems have a 3 year warranty against defects in material and workmanship. For complete warranty information contact OptiPure customer service or go to www.optipurewater.com.

OptiPure, Mfg. by Procam Controls, Inc.
2605 Technology Dr., Bldg 300
Plano, TX 75074
p: 972.881.9797; f: 972.422.6262
www.optipurewater.com

Dealer/Distributor Info: