

## Snapshot

The **FX-12** is a single housing water treatment system with a drop-in 20" cartridge that is NSF Certified under Standard 42 to reduce sediment down to 0.5 micron and to reduce chlorine, taste & odor at a flow rate of 3.0 gpm for 30,000 gallons.

## System Benefits

- Improves the quality and consistency of cold and hot beverages.
- Reduces maintenance frequency and cost, and extends equipment life.
- Gradient-density depth filtration reduces dirt, rust, and other debris as small as 1/2 micron to assure clean, clear water and protect solenoids, valves and other fittings against wear and plugging.
- High capacity activated carbon filtration makes water taste great and protects equipment against corrosive chlorine.
- Reduced sediment, chlorine and taste & odor can improve beverage ingredient efficiency.
- Stainless steel mounting bracket and full-flow inlet shut-off valve makes installation simple.
- Built-in pressure gauge allows visual monitoring of operating pressure.
- Inlet shut-off and depressurization valves make changing the filter quick and simple.
- Only the drop-in cartridge is replaced. No discarding of metal or plastic quick-change filters.
- Replacement cartridge cost per gallon is much less than proprietary quick-change filters.
- NSF Certified under Standard 42.

ITEM #: \_\_\_\_\_ QTY: \_\_\_\_\_  
JOB NAME/NUMBER \_\_\_\_\_



## Application

FOUNTAIN BEVERAGES - *Up to two carbonators.*

COFFEE & TEA - *High volume brewer applications where water hardness is not a problem.*

DRINKING WATER - *High volume dedicated point-of-use.*

## Installation Tips

- Feed-water connection to system should be COLD only.
- Do not exceed system specifications for temperature and pressure.
- Allow 3" clearance below system for filter housing removal and cartridge replacement.
- Connect filtered water line to ice and steam production connections only. Do not use for condenser water.
- Detailed installation, operation & maintenance manual is included with each system.
- No activation procedure or flushing is required for system to perform as specified.

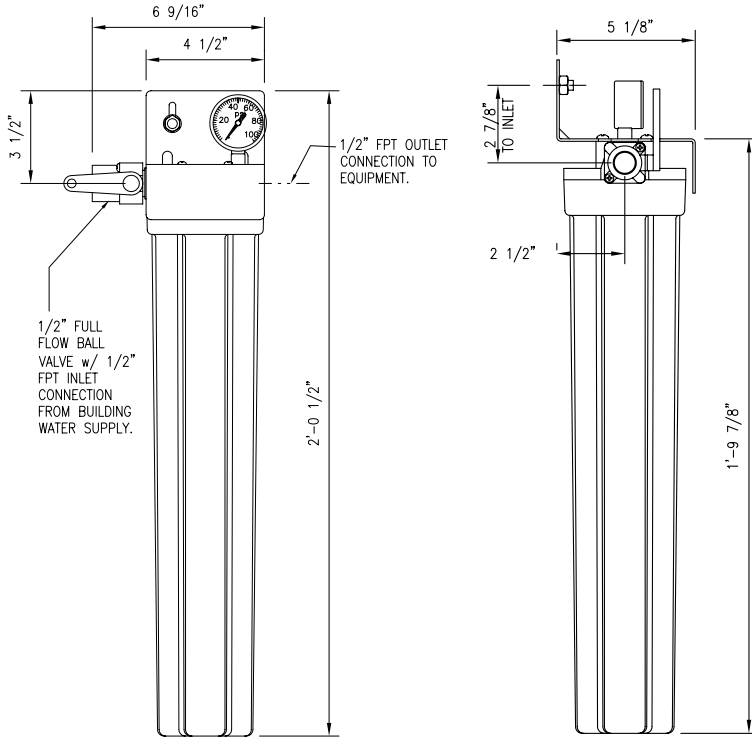

Model FX-12 is tested and certified by NSF International against NSF/ANSI Standard 42 for the reduction of:  
Standard 42: Aesthetic Effects,  
Chlorine Reduction  
Taste and Odor Reduction  
Nominal Particulate Reduction, Class 1

Dealer/Distributor Info:

## ► Specifications

System	
Dimensions (Height x Width X Depth, inches)	24 1/2" x 6 9/16" x 5 1/8"
Connection - Inlet & Outlet	1/2" NPT female
Operating Pressure Range	10-125 psi (0.7 -8.6 bar)
Inlet Water Temperature Range	35° -100° F (2° -38° C)
Shipping Weight	8 lbs.
Performance	
Chlorine, Taste and Odor Reduction Capacity	30,000 gals (113,400 liters)
Service Flow Rate	3.0 gpm (11.3 lpm)
Sediment Reduction	.5 micron (nominal)

## ► Replacement Cartridge(s)

Model	Part Number	Qty
CTO-20	252-20120	1

It is recommended that filters be changed every six months, when capacity is reached or when effluent pressure or flow becomes inadequate.

This product is for commercial use only and must be installed and maintained according to manufacturers guidelines.

Do not use on water that is microbiologically unsafe or of unknown quality without adequate disinfection before or after the system.

## ► Warranty

Systems have a 3 year warranty against defects in material and workmanship. For complete warranty information refer to the warranty statement included with each system.

**OptiPure, Mfg. by Procam Controls, Inc.**  
2605 Technology Dr., Bldg 300  
Plano, TX 75074  
p: 972.881.9797; f: 972.422.6262  
[www.optipurewater.com](http://www.optipurewater.com)