

Snapshot

The **FXI-22P+** is a three housing water treatment system with drop-in 20" cartridges that is NSF Certified under Standard 42 to reduce sediment down to 0.5 micron and to reduce chlorine, taste & odor at a flow rate of 6.0 gpm for 60,000 gallons. The system includes IsoNet[®], OptiPure's patented scale inhibiting technology, which delivers consistent protection against the precipitation and accumulation of scale and provides a protective barrier to help guard against corrosion.

System Benefits

- IsoNet[®] - OptiPure's patented scale inhibiting technology helps protect equipment against scale and corrosion for the rated capacity of the system.
- Reduces maintenance frequency and cost, and extends equipment life.
- Gradient-density depth filtration reduces dirt, rust, and other debris as small as 1/2 micron to assure clean, clear water and protect solenoids, valves and other fittings against wear and plugging.
- 5-micron Polytrix prefilter provides added protection against excessive sediment found in some water supplies.
- High capacity activated carbon filtration makes water taste great and protects equipment against corrosive chlorine.
- Improves equipment operating efficiency.
- White powder coated heavy gauge steel mounting bracket and full-flow inlet shut-off valve makes installation simple.
- Built-in pressure gauge allows visual monitoring of operating pressure.
- Inlet shut-off and depressurization valves make changing the filters quick and simple.
- Only the drop-in cartridges are replaced. No discarding of metal or plastic quick-change filters.
- Replacement cartridge cost per gallon is much less than proprietary quick-change filters.
- NSF Certified under Standard 42.

ITEM #: _____ QTY: _____
JOB NAME/NUMBER _____



Application

ICE - High production cubers up to 2,400 lbs. and flakers up to 4,000 lbs. Includes prefilter for water supplies with high turbidity levels.

Installation Tips

- Feed-water connection to system should be COLD only.
- Do not exceed system specifications for temperature and pressure.
- Allow 3" clearance below system for filter housing removal and cartridge replacement.
- Connect filtered water line to ice connections only. Do not use for condenser water.
- Detailed installation, operation & maintenance manual is included with each system.
- No activation procedure or flushing is required for system to perform as specified.

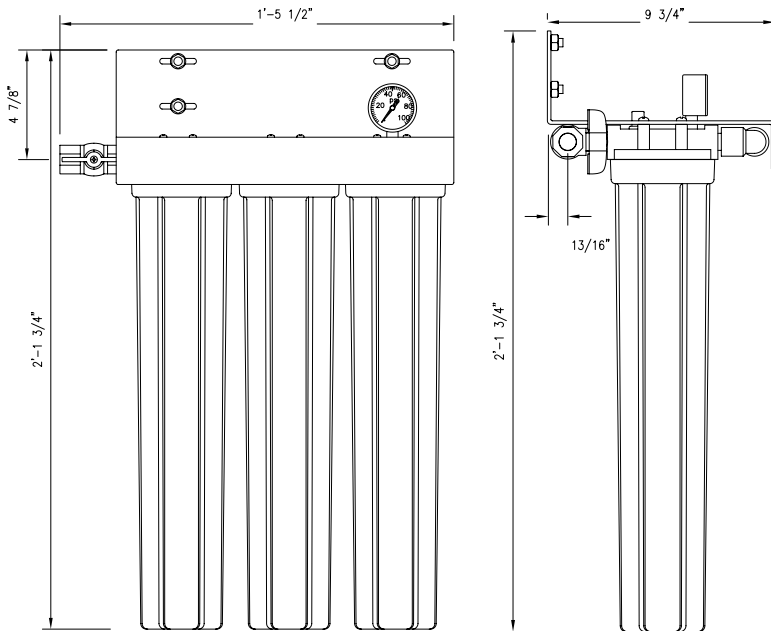

Model FXI-22P+ is tested and certified by NSF International against NSF/ANSI Standard 42 for the reduction of:
Standard 42: Aesthetic Effects, Chlorine Reduction
Taste and Odor Reduction
Nominal Particulate Reduction, Class 1

Dealer/Distributor Info:

► Specifications

System	
Dimensions Height x Width X Depth, inches	25 3/4" x 17 1/2" x 9 3/4"
Connection - Inlet & Outlet	1/2" NPT female
Operating Pressure Range	10-125 psi (0.7 -8.6 bar)
Inlet Water Temperature Range	35° -100° F (2° -38° C)
Shipping Weight	30 lbs.
Performance	
Chlorine, Taste and Odor Reduction Capacity	60,000 gals (226,800 liters)
Service Flow Rate	6.0 gpm (22.7 lpm)
Sediment Reduction	.5 micron (nominal)
Scale & Corrosion Inhibitor	IsoNet (280 grams)

► Replacement Cartridge(s)

Model	Part Number	Qty
S5-20	252-10120	1
CTOS-20	252-20220	2

It is recommended that filters be changed every six months, when capacity is reached or when effluent pressure or flow becomes inadequate.

This product is for commercial use only and must be installed and maintained according to manufacturers guidelines.

Do not use on water that is microbiologically unsafe or of unknown quality without adequate disinfection before or after the system.

► Warranty

Systems have a 3 year warranty against defects in material and workmanship. For complete warranty information refer to the warranty statement included with each system.

OptiPure, Mfg. by Procam Controls, Inc.
2605 Technology Dr., Bldg 300
Plano, TX 75074
p: 972.881.9797; f: 972.422.6262
www.optipurewater.com