

OptiPure[®]

Foodservice Filtration Systems

Snapshot

The CTOS-CK is a replacement cartridge for the Cuno[®] 8000 series filter replacement cartridges. It is a 16" quick-change cartridge that reduces sediment down to 0.5 micron and reduces chlorine, taste & odor at a flow rate of 2.25 gpm for 22,500 gallons. The cartridge includes IsoNet[®], OptiPure's patented scale-inhibiting technology, which delivers consistent protection against the precipitation and accumulation of scale and provides a protective barrier to help guard against corrosion.

Cartridge Benefits

- IsoNet[®] - OptiPure's patented scale inhibiting technology delivers up to 5 times more protection against scale and corrosion.
- Higher capacity cartridge extends filter system life reducing maintenance frequency.
- Gradient-density depth filtration reduces dirt, rust, and other debris as small as 1/2 micron to assure clean, clear water and protect solenoids, valves and other fittings against wear and plugging.
- Activated carbon filtration makes water taste great and protects equipment against corrosive chlorine.
- Improves equipment operating efficiency by reducing scale and corrosion.
- Replaces 3M[®] Cuno[®] 8000 Series sanitary quick change cartridges that include scale inhibition.

Model: **CTOS-CK**
Part #: 300-08025

REPLACEMENT CARTRIDGE

ITEM #: _____ QTY: _____

JOB NAME/NUMBER _____



Application

- Replacement cartridge for 3M[®] Cuno[®] 8112S, 8112ELS, 8112XS, 8720S, 8720ELS cartridges.
- Ice machines, coffee brewers and steam equipment.

Installation Tips

- Insure cartridge is designed to replace the existing cartridge.
- Do not exceed cartridge specifications for temperature and pressure.
- Allow 3" clearance below system for filter cartridge removal and replacement.
- No activation procedure or flushing is required for cartridge to perform as specified.
- Feed-water connection to system should be COLD only.

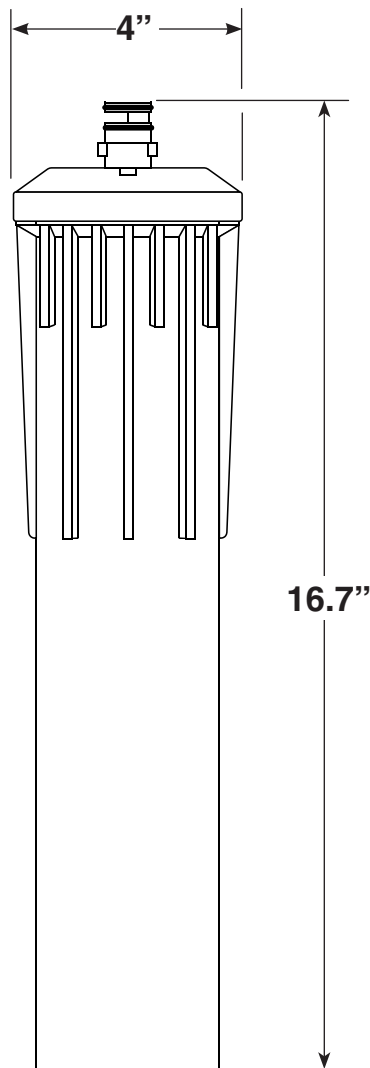

Do not use on water that is microbiologically unsafe or of unknown quality without adequate disinfection before or after the system.

This product is for commercial use only and must be installed and maintained according to manufacturers guidelines.

Cartridges must be changed every 12 months, when capacity is reached or when effluent pressure or flow becomes inadequate.

Dealer/Distributor Info:

OptiPure, Mfg. by Procam Controls, Inc.
2605 Technology Dr., Bldg 300 Plano, TX 75074
p: 972.881.9797; f: 972.422.6262
www.optipurewater.com

► Specifications

Cartridge	
Dimensions (Height x Width X Depth, inches)	16.7" x 4" x 4"
Operating Pressure Range	10-125 psi (0.7 -8.6 bar)
Inlet Water Temperature Range	35° -100° F (2° -38° C)
Shipping Weight	5 lbs.
Performance	
Chlorine, Taste and Odor Reduction Capacity	22,500 gals. (85,162 liters)
Service Flow Rate	2.25 gpm (8.5 lpm)
Sediment Reduction	.5 micron (nominal)
Scale & Corrosion Inhibitor	IsoNet® (100 grams)

► System(s) Cartridge Used In

Model	Part Number	Qty
IA1-1	55731-01	1
IA2-5	55731-02	1
IA2-1	55966-01	2
IA2-5	55966-02	2
IA3-1	55967-01	3
IA3-5	55967-02	3
IA4NV-ELS	55839-15	4
CFS6112-S	55889-07	1
CFS6812-S	55889-17	1
CFS6720-S	55889-05	1
2S	55837-02	2
2SC	55837-07	2
2SP	55837-07	2
CFS8576-S	55819-06	1
CFS7812-S	55819-17	1
CFS7720-S	55819-12	1

► Warranty

OptiPure Cartridges are warranted against defects in material and workmanship up to one year or when cartridge capacity is reached. Claims of capacity or rated service life are not applicable for mechanical filtration. Contact OptiPure customer service or go to the OptiPure website for a copy of the warranty.