

Snapshot

The **SX2-12** is a single housing water treatment system with a drop in 20" cartridge. The system utilizes ScaleX2[®], a chemical-free scale inhibition technology that utilizes Template Induced Crystallization to effectively inhibit the formation of calcium-carbonate scale. The SX2-12 is ideal for applications requiring up to 2 gpm flow. In most cases, the cartridge will perform for one-year between filter changes.

System Benefits

- ScaleX2[®], achieved a 99.6% effectiveness rating when tested by an independent laboratory against the international protocol for scale prevention.
- Protects boilers, steam generators, and coffee equipment against the formation and accumulation of calcium-carbonate scale.
- Reduces maintenance frequency and cost, and extends equipment life.
- Sturdy mounting bracket and full-flow inlet shut-off valve makes installation simple.
- Inlet shut-off and depressurization valve make changing the filter quick and simple.
- Generates less waste, only the drop-in filter is replaced. No discarding of metal or plastic quick-change filters.

ITEM #: _____ QTY: _____
JOB NAME/NUMBER _____



Application

STEAM & COMBI OVENS - *boilers or steam generators up to 2 gpm. Not recommended for 'flash' type (boilerless) combi ovens.*

COFFEE BREWERS - *Single or combination applications up to 2 gpm.*

COMBINATION - *Can be used down-line in conjunction with a primary filtration system. Do not use ScaleX2 with any type of polyphosphate based scale inhibitor filter.*

Installation Tips

- Feed-water connection to system should be **COLD** only.
- Do not exceed system specifications for temperature and pressure.
- Allow 3" clearance below system for filter housing removal and cartridge replacement.
- Connect filtered water line to ice and steam production connections only. **Do not use for condenser water.**
- Detailed installation, operation & maintenance manual is included with each system.
- No activation procedure or flushing is required for system to perform as specified.

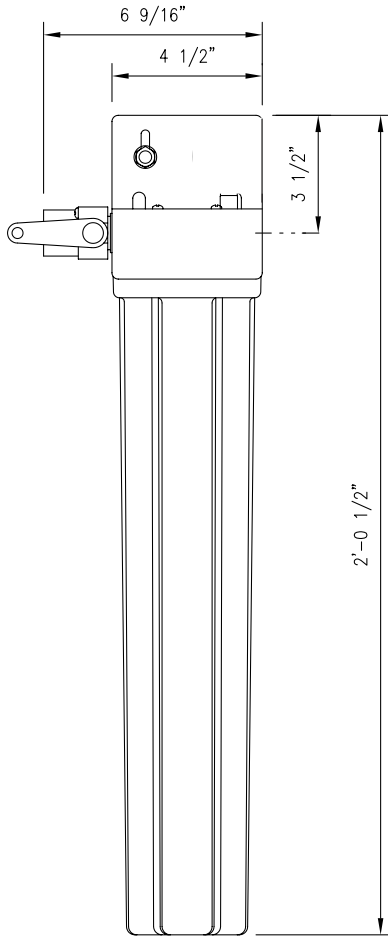

The ScaleX2 element is tested and certified by NSF International against NSF/ANSI Standard 42 for material requirements only.

► Specifications

System	
Dimensions (Height x Width X Depth, inches)	24 1/2" x 6 9/16" x 5 3/4"
Connection - Inlet & Outlet	1/2" NPT female
Operating Pressure Range	10-125 psi (0.7 -8.6 bar)
Inlet Water Temperature Range	35° -100° F (2° -38° C)
Shipping Weight	8 lbs.
Performance	
Chlorine, Taste and Odor Reduction Capacity	N/A
Service Flow Rate	2.0 gpm (7.6 lpm)
Sediment Reduction	N/A
Scale Inhibitor	ScaleX2®

► Replacement Cartridge(s)

Model	Part Number	Qty
SCLX2-2	252-60210	1

In most applications, the ScaleX2 cartridge should be changed annually.

This product is for commercial use only and must be installed and maintained according to manufacturers guidelines.

Do not use on water that is microbiologically unsafe or of unknown quality without adequate disinfection before or after the system.

► Warranty

Systems have a 3 year warranty against defects in material and workmanship. For complete warranty information contact OptiPure customer service or go to www.optipurewater.com.

Dealer/Distributor Info:

OptiPure, Mfg. by Procam Controls, Inc.
2605 Technology Dr., Bldg 300
Plano, TX 75074
p: 972.881.9797; f: 972.422.6262
www.optipurewater.com