

DO NOT DISCARD - GIVE THIS MANUAL TO THE OWNER AFTER INSTALLATION.

DO NOT DISCARD THIS MANUAL AFTER INSTALLATION. THIS MANUAL CONTAINS IMPORTANT OPERATION, MAINTENANCE AND PRECAUTIONARY INFORMATION. PLEASE PRESENT THIS MANUAL TO USER/OPERATOR/OWNER AFTER INSTALLATION.

IT IS STRONGLY ENCOURAGED THAT YOU READ THIS MANUAL BEFORE INSTALLING SYSTEM TO ENSURE THE BEST POSSIBLE INSTALLATION.

INSTALLATION MUST CONFORM TO ALL LOCAL AND STATE PLUMBING CODES AND REGULATIONS. CONNECT SYSTEM TO COLD WATER SUPPLY ONLY. WATER TEMP. CAN NOT EXCEED 100°F/38°C.

SYSTEM MUST BE INSTALLED IN A VERTICAL AND UPRIGHT POSITION.

SCALEX2® SYSTEMS MUST NOT BE USED IN CONJUNCTION WITH POLYPHOSPHATE OR ANY OTHER SCALE INHIBITOR.

DO NOT INSTALL FILTERS DOWNLINE FROM THE SCALEX2® SYSTEM. SCALEX2® MUST BE THE LAST FILTER SYSTEM BEFORE THE EQUIPMENT.

DO NOT USE WITH WATER THAT IS MICROBIOLOGICALLY UNSAFE OR OF UNKNOWN QUALITY WITHOUT ADEQUATE DISINFECTION BEFORE OR AFTER THE SYSTEM.

FAILURE TO CHANGE CARTRIDGES PER RECOMMENDED INTERVALS WITH OPTIPURE REPLACEMENT CARTRIDGES MAY LEAD TO SYSTEM FAILURE AND PROPERTY DAMAGE.

Introduction

Your new OptiPure ScaleX2® FoodService Filtration System will condition the tap water providing optimum water characteristics for their specified applications. The result is reduced equipment maintenance requirements, longer equipment life and improved quality & consistency of your products. Proper system installation and routine filter changes will ensure years of trouble-free operation and performance.

The ScaleX2® System is built with the finest and most advanced materials and each system is quality inspected and pressure tested prior to shipment. With proper installation and routine maintenance, you will have years of trouble-free operation.

Please refer to this manual when performing routine filter changes. The instructions make periodic maintenance quick and easy, and ensure you will receive maximum benefit from your system.

System Specifications & Dimensions

Maximum Pressure: 125 psi/8.6 bar

Maximum Temperature: 100°F/38°C, Min.: 35°F/2°C

Inlet/Outlet Connections: 1/2" fnt

Capacity: Change ScaleX2® Cartridge at least once a year. Change CTO cartridges at gallon rating or at least every 6 months or when pressure gauge needle enters the red zone on the outlet gauge while water is flowing through the filter system under normal operating conditions.

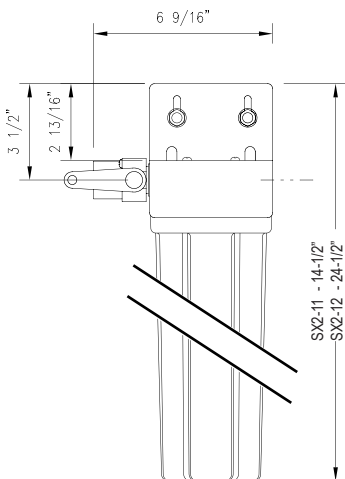

Model: SX2-11

Capacity: 12 Months

Service Flow Rate: 1.0 gpm/3.8 lpm

Model: SX2-12

Capacity: 12 Months

Service Flow Rate: 2.0 gpm/7.5 lpm

Installation Precautions

- Do **NOT** install system on line pressure above 125 psi.
- Do **NOT** install the system backwards with the feed water line connected to the outlet.
- Do **NOT** use liquid pipe compounds for fitting connections. USE a maximum of two to three wraps of teflon tape.
- Do **NOT** allow system to freeze. Turn off water supply to housing and drain housing if temperature falls below 32°F.
- Do **NOT** install system in direct sunlight or where system is exposed to harsh chemicals or may be subjected to being struck by moving equipment, carts, mops or any other item that may cause damage.
- **IF** water hammer is evident, install water hammer arrestors before OptiPure unit.
- Do **NOT** overtighten fitting connections into inlet valve or housing outlet.
- **Always** back-up valves and fittings with a wrench when installing a fitting to avoid turning the valve.

Position the OptiPure unit in a suitable location downstream from existing filters. The direction of flow through the OptiPure unit is always left to right; keep this in mind when determining installation location. Do NOT mount the OptiPure system near any source of heat. Also, do not mount the system above any device or area that would be adversely affected by water.

Installation Procedure

1. Turn off all equipment to be fed by the ScaleX2® System, locate water supply cut-off valve and turn off.
2. **Determine if water line has an existing water treatment system. If so, examine system for use of polyphosphate or other scale inhibitors. ScaleX2® will not be effective if used in conjunction with other scale inhibitors. Remove the scale inhibitors from the water line or discontinue installation.**
3. Install a 1/2" full-flow ball valve on the water supply side that will feed the water system.
4. Anchor the ScaleX2® System on a wall stud or suitable mounting material spanning wall studs. **System must be upright and vertical.**
5. Run a suitable line from the 1/2" full-flow ball valve at the tap water source to the inlet ball valve on the left side of the ScaleX2® system. Use 2-3 wraps of teflon tape and brace the inlet ball valve on the system with a wrench when connecting the feed water line. **NOTE: DO NOT OVERTIGHTEN CONNECTION FITTING INTO BALL VALVE.**
6. Select the appropriate size tubing for the equipment being fed and connect it to the outlet of the ScaleX2® System. **NOTE: DO NOT** connect the tubing to the equipment at this time. Prior to making connection to the equipment this line will be used to facilitate flushing the system. As an option, a drain valve in a tee on the outlet side of the ScaleX2® system could be provided in the line to facilitate flushing when changing filters.
7. With System inlet valve closed, slowly open the 1/2" full-flow ball valve at the tap water source. Check for leaks.
8. If a drain valve was not installed on the outlet side of the system, hold the tubing that will connect to equipment in a clean bucket or over sink or drain. Open the system inlet feed valve and allow water to flush through system for 10 minutes at the specified system flow rate to allow air and any carbon fines to escape. **NOTE:**

NO ACTIVATION IS REQUIRED FOR THE OPTIPURE SYSTEM TO PERFORM PROPERLY. FLUSHING IS RECOMMENDED TO ALLOW AIR TO ESCAPE THE SYSTEM AND REMOVE ANY CARBON FINES PRIOR TO CONNECTING TO EQUIPMENT.

9. Make certain that the end of the tubing to be connected to the equipment is clean and sanitized.
10. Connect tubing to equipment. Open all water supply valves and check for leaks.
11. If no leaks turn on equipment and check for normal operation.
12. Register your warranty using the enclosed warranty card or go to www.filterexpress.com

Operation

With adequate pressure, normal operation of the ScaleX2® System is completely automatic. Dependable operation involves only periodic filter changes and service documentation.

Maintenance

The only routine maintenance your ScaleX2® System should ever require is periodic filter cartridge changes or replacement sump O-rings. Filter changes are necessary for optimum performance of your foodservice equipment. If the system sizing recommendations have been followed the ScaleX2® System is designed to provide a twelve (12) month filter replacement interval on most tap water.

Filter Change Frequency

Several situations will mandate filter changes. Complete filter sets should be changed when any of the following apply:

- Twelve (12) Months have passed since unit installation or previous filter change.
- Reduced water flow.

If filter change frequency is less than 12 months due to pressure drop, it may be necessary to add additional prefiltration or evaluate system sizing recommendations.

Filter Cartridge Replacement Procedure

IMPORTANT: Determine whether all equipment connected to the ScaleX2® System must be turned off prior to shutting off water supply from filters.

1. If required, turn off equipment.
2. Turn OFF water to ScaleX2® System by closing Inlet Ball Valve.
3. Press the red button to release pressure.
4. Remove housing(s) - use filter wrench if necessary.
5. Clean inside of housing sumps with warm water. If desired, disinfect housings using a teaspoon of household bleach in a filter bowl of water. Let stand 5 minutes, and then discard.
6. Insert new cartridges into filter housings. Match cartridge model numbers to model numbers on bracket.
7. Make certain the O-ring is properly positioned and reinstall filter housings (hand tighten only). Check O-ring for damage and replace if damaged or distorted.
8. Slightly open the inlet ball valve; push the red pressure relief button to release trapped air until a small amount of water comes out - release the red button and fully open the ball valve.
9. Open the flush valve downline from the filter housing (if equipped) and flush the new cartridges to drain or bucket for five (5) minutes or until water runs clear. If no flush valve is present, disconnect line from equipment to flush to drain.
10. **VERY IMPORTANT:** With water supply inlet valve OPEN and water flow confirmed, turn on connected equipment. Failure to supply water to equipment may cause serious damage.
11. Record filter change on the service log or at FilterTrak.

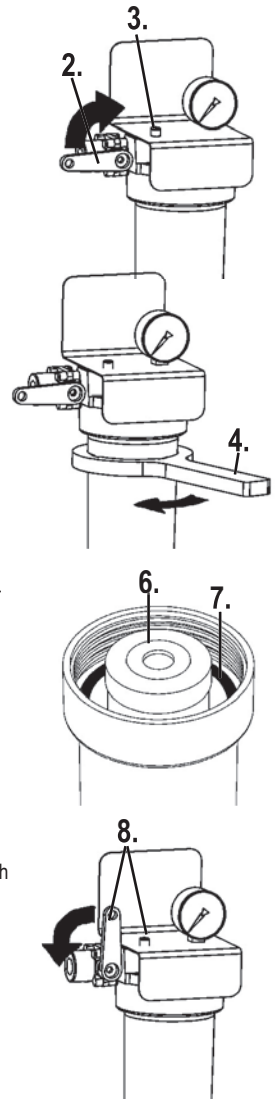

Replacement Filter Cartridges

OptiPure Filter Systems are designed, tested, and certified with FilterXpress filter cartridges with proven performance, size and operating capacities. Use of replacement cartridges other than those specified will void warranties, certifications and may compromise equipment protection, water quality and cartridge life.

Replacement Parts for: SX2-11, SX2-12, SX2-12B

Part #	Description
600-10050	Sump for SX2-11
600-10059	Sump for SX2-12
600-10014	Sump for SX2-12B
600-99003	O-Ring - for SX2-11 & 12
600-99004	O-Ring - for SX2-12B
520-12055	Valve, Inlet Ball for SX2-11, 12
520-12010	Valve, Inlet Ball for SX2-12B
600-99007	Wrench for SX2-11, 12
600-99009	Wrench for SX2-12B
600-99205	Pressure Relief Button Kit

ScaleX2.

Replacement Cartridges

System	Cartridge	Qty
SX2-11	SCLX2-1	1
SX2-12	SCLX2-2	1
SX2-12B	SCLX2-4	1



FilterTrak - Filter System Management Resource

The single biggest problem with filter systems is the lack of attention after the system is installed. Many times the equipment supplied by the filter systems has a service problem related to water because the filter system has not been maintained. This is simply because personnel in the establishment change and it becomes difficult to keep track of what filters are needed and when. FilterTrak eliminates this problem since it automatically notifies users when a scheduled filter change is due and what filter cartridges are needed via mail, fax, email or autoship.



The ScaleX2® filter cartridge in the SX2-11 and SX2-12 is Tested and Certified by NSF International against NSF/ANSI Standard 42 for materials and structural integrity requirements only.

NOTE: Testing was performed under standard laboratory conditions, actual performance may vary. It is recommended that you have your water supply tested to determine your actual water treatment requirements.

OptiPure warrants the quality of workmanship of their system components and assembly, except for replacement cartridges and membranes, for a period of 36 months. OptiPure Systems are designed, tested and certified with OptiPure cartridges. Use of replacement cartridges or parts other than those specified will void warranties and Certifications, and compromise equipment protection, water quality and cartridge life.

Manufactured by OptiPure

division of Procram Controls, Inc.

2605 Technology Dr. Bldg. 300 Plano, TX 75074 USA

P: 972.881.9797 F: 972.422.6262 email: techsupport@optipure.net

www.optipurewater.com