

Snapshot

The OptiPure® BWS100/16 is a Blended Water System that utilizes reverse osmosis (RO) to remove >97% of the total dissolved solids (TDS) from water which can be precisely blended with filtered water to a user determined TDS level. The system operates at line pressure and can produce up to 100+ gallons per day of optimal quality water for applications where TDS reduction or the removal of the majority of hardness minerals is required. The BWS100/16 is a complete system that includes integrated pre-filtration with particulate and chlorine reduction, the Advanced Membrane Separation (AMS) Processor and final post-filtration in a space saving, wall-mount or undercounter design. Also included is a 16 gallon pressurized sealed storage tank and sample port. Hose, tubing and fittings required for installation are included.

System Benefits

- Virtually eliminates scale & corrosion problems related to high TDS & water hardness.
- The system utilizes an integrated permeate pump in a unique hydraulic design that assures consistent production and blend accuracy.
- High capacity pre-filtration protects the membrane against damaging chlorine and reduces filter replacement frequency.
- Compact, Modular Design enables installation under counters and in very tight spaces.
- Three different mounting locations enables the Water Quality Monitor to be easily viewed in any installation.
- Precision Blending Valve allows the user to accurately and precisely blend a calculated amount of filtered water with the RO product water.
- Digital before and after TDS meter for push-button monitoring of membrane performance and optimized water quality.
- Built-in pressure gauge allows visual monitoring of operating pressure.
- Non-electric design operates on available water pressure.
- All consumables are easy-to-change Qwik-Twist cartridges.
- Simple, easy-to-service and maintain design.

ITEM #: _____ QTY: _____

JOB NAME/NUMBER _____



Application

Water quality can be adjusted to provide ideal water for espresso and coffee applications, counter-top combi ovens or any application where high quality water and the ability to manage total dissolved solids level is desired.

Installation Tips

- Feed-water connection to system should be COLD only.
- Do not exceed system specifications for temperature and pressure.
- Provide a dedicated 1/2" water line to the unit to consistent flow and pressure to the system.
- Allow 3" clearance below system for filter cartridge removal and replacement.
- Connect filtered water line to steam production connections only. Do not use for condenser water.
- Detailed installation, operation & maintenance manual is included with each system.
- Mount the BWS100/16 Water Quality Monitor where it can be easily viewed and accessed.

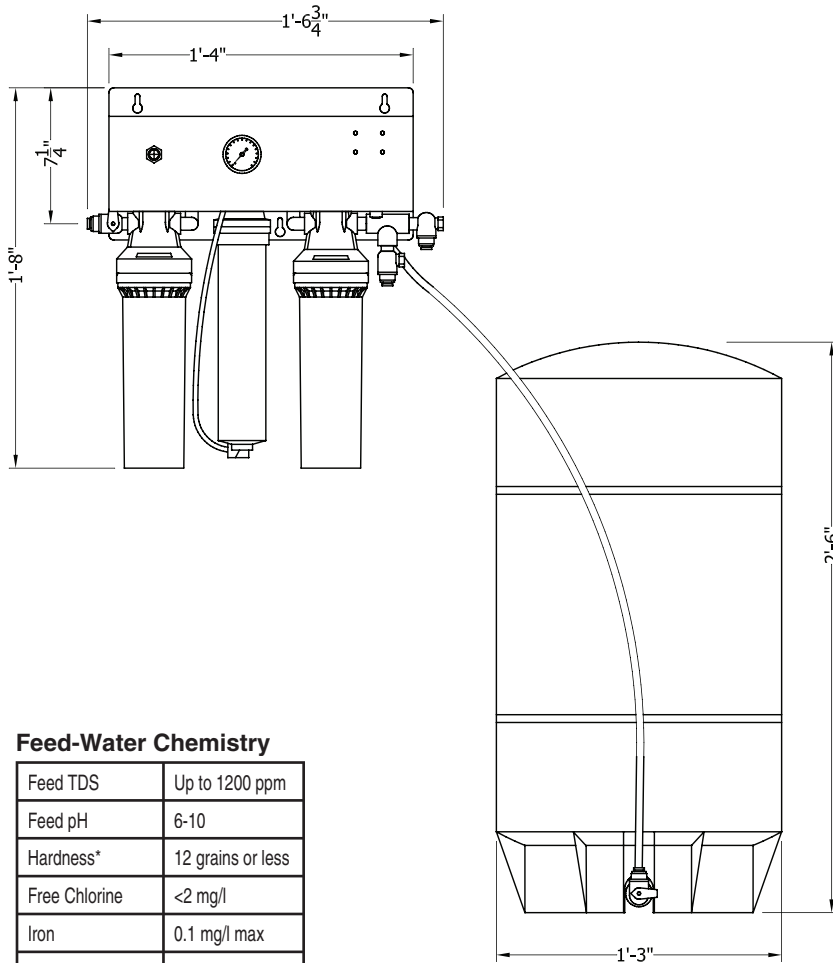

Feed-Water Chemistry

Feed TDS	Up to 1200 ppm
Feed pH	6-10
Hardness*	12 grains or less
Free Chlorine	<2 mg/l
Iron	0.1 mg/l max
Turbidity	0.05 NTU
Manganese	0.05 mg/l max
Hydrogen Sulfide	0.0 mg/l

*For water outside of these parameters call OptiPure technical service.

Specifications

System		
Dimensions	Processor Tank	20"hx18.5"wx6"d 30"hx15"dia.
Connection - Feedwater		3/8" Push Fit Tubing
Operating Pressure Range		60-85 psi at 0.5 gpm (3.5 -5.9 bar)
Inlet Water Temperature Range		40° -100° F (4° -38° C)
Shipping Weight		25 lbs.
Drain Connection (Within 5' of unit)		2 GPM Minimum Flow
Performance		
Typical TDS* Rejection		97+%
Product Water Production (at 77°F, 60psi)		75 gals/day 3.1 gals/hr 0.052 gpm
		<i>Production rate is strictly dependent on feed water temperature and pressure.</i>
Blended Water Production		100+ GPD

Replacement Media

Description	Part Number	Qty
Pre/Post Filter	300-05828	2
AMS Membrane	204-52810	1

It is recommended that Pre-Filter be changed every 3-6 months, when capacity is reached or when feedwater pressure or flow becomes inadequate. Membrane life varies depending on feedwater conditions and PreFilter maintenance. 12-18 months under typical conditions but it can be as long as 3-5 years.

This product is for commercial use only and must be installed and maintained according to manufacturers guidelines.

Do not use on water that is microbiologically unsafe or of unknown quality without adequate disinfection before or after the system.

Warranty

Systems have a 1 year warranty against defects in material and workmanship. Warranty does not include filters or membranes. For complete warranty information contact OptiPure customer service or go to the OptiPure website.

Dealer/Distributor Info: