

Snapshot

The **QTCI-1** is a single cartridge water treatment system with a 15" Qwik-Twist cartridge that reduces sediment down to 0.5 micron and reduces chlorine, taste & odor at a flow rate of 2.25 gpm for 22,500 gallons. The system also reduces turbidity and health-related contaminants such as cysts. The system includes IsoNet®, OptiPure's patented scale inhibiting technology, which delivers consistent protection against the precipitation and accumulation of scale and provides a protective barrier to help guard against corrosion.

System Benefits

- IsoNet® - OptiPure's patented scale inhibiting technology helps protect equipment against scale and corrosion for the rated capacity of the system.
- Reduces maintenance frequency and cost, and extends equipment life.
- Gradient-density depth filtration reduces dirt, rust, and other debris as small as 1/2 micron to assure clean, clear water and protect solenoids, valves and other fittings against wear and plugging.
- High capacity activated carbon filtration makes water taste great and protects equipment against corrosive chlorine.
- Improves equipment operating efficiency.
- Mounting bracket and full-flow inlet shut-off valve makes installation simple.
- 1/4 turn QT 'Qwik-Twist' bayonet cartridge makes changing the filter quick, easy and sanitary.
- NSF Certified under Standard 42 and 53.

ITEM #: _____ QTY: _____
JOB NAME/NUMBER _____



Application

ICE - *Cubers up to 1,000 lbs, flakers up to 1,500 lbs.*
COFFEE - *Applications up to 2.25 gpm.*

Installation Tips

- Feed-water connection to system should be COLD only.
- Do not exceed system specifications for temperature and pressure.
- Allow 3" clearance below system for filter cartridge removal and replacement.
- Detailed installation, operation & maintenance manual is included with each system.
- No activation procedure or flushing is required for system to perform as specified.

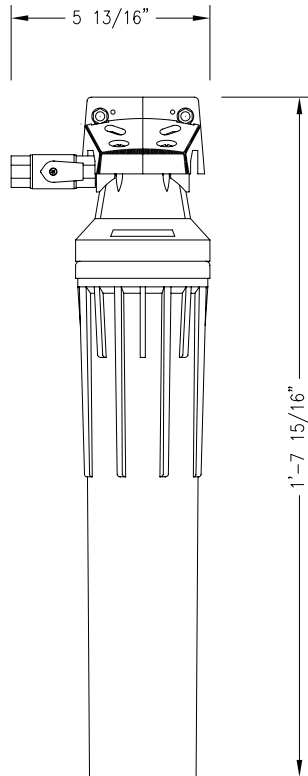

Model QTCI-1 is tested and certified by NSF International against NSF/ANSI Standard 42 for the reduction of:
Standard 42: Aesthetic Effects,
Chlorine Reduction
Taste and Odor Reduction
Nominal Particulate Reduction, Class 1
Standard 53: Health Effects,
Mechanical Filtration
Cyst & Turbidity Reduction

Dealer/Distributor Info:

► Specifications

System	
Dimensions (Height x Width X Depth, inches)	19 15/16" x 5 13/16" x 4 1/6"
Connection - Inlet & Outlet	3/8" NFPT
Operating Pressure Range	10-125 psi (0.7 -8.6 bar)
Inlet Water Temperature Range	35° -100° F (2° -38° C)
Shipping Weight	5 lbs.
Performance	
Chlorine, Taste and Odor Reduction Capacity	22,500 gals. (85,162 liters)
Service Flow Rate	2.25 gpm (8.5 lpm)
Sediment Reduction	.5 micron (nominal)
Reduces Harmful Cysts Reduces Turbidity	
Scale & Corrosion Inhibitor	IsoNet (60 grams)

Optional Flush Valve Kit - Part #: 160-52912
Optional Gauge Kit - Part #: 160-52904

► Replacement Cartridge(s)

Model	Part Number	Qty
XTOS-Q	300-05845	1

It is recommended that filters be changed every six months, when capacity is reached or when effluent pressure or flow becomes inadequate.

This product is for commercial use only and must be installed and maintained according to manufacturers guidelines.

Do not use on water that is microbiologically unsafe or of unknown quality without adequate disinfection before or after the system.

► Warranty

Systems have a 3 year warranty against defects in material and workmanship. Contact OptiPure customer service or go to the OptiPure website for a copy of the warranty.

OptiPure, Mfg. by Procam Controls, Inc.
2605 Technology Dr., Bldg 300
Plano, TX 75074
p: 972.881.9797; f: 972.422.6262
www.optipurewater.com