

Snapshot

The QTTS-1 is a single cartridge water treatment system with a 10" Qwik-Twist cartridge that reduces sediment down to 5 micron. The system includes IsoNet[®], OptiPure's patented scale inhibiting technology, which delivers consistent protection against the precipitation and accumulation of scale and provides a protective barrier to help guard against corrosion.

System Benefits

- IsoNet[®] - OptiPure's patented scale inhibiting technology helps protect equipment against scale and corrosion for the rated capacity of the system.
- Reduces maintenance frequency and cost, and extends equipment life.
- Five micron PolyTrix Qwik-Twist sediment filtration provides added protection against excessive sediment found in some water supplies.
- Improves equipment operating efficiency.
- Mounting bracket and full-flow inlet shut-off valve makes installation simple.
- 1/4 turn QT 'Qwik-Twist' bayonet cartridge makes changing the filter quick, easy and sanitary.
- NSF Certified under Standard 42.

ITEM #: _____ QTY: _____
JOB NAME/NUMBER _____



Application

COMBINATION APPLICATIONS - (Secondary Filtration) - Provides protection against scale and corrosion.

ICE - Cuber up to 800 lbs., Flaker up to 1200 lbs.
- Where chlorine reduction is not required.

Installation Tips

- Feed-water connection to system should be COLD only.
- Do not exceed system specifications for temperature and pressure.
- Allow 3" clearance below system for filter housing removal and cartridge replacement.
- Detailed installation, operation & maintenance manual is included with each system.
- No activation procedure or flushing is required for system to perform as specified.

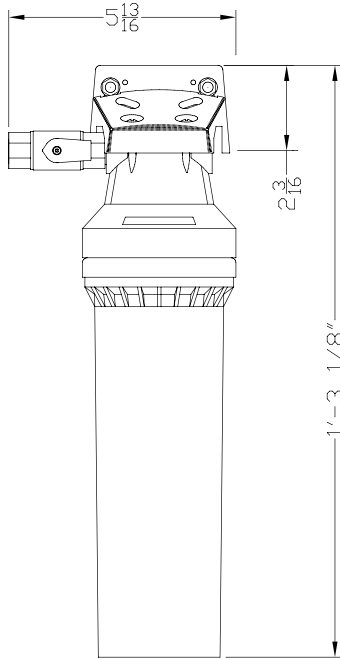

COMPONENT

Dealer/Distributor Info:

► Specifications

System	
Dimensions (Height x Width X Depth, inches)	15.2 x 5.8 x 4.2"
Connection - Inlet & Outlet	3/8" NFPT
Operating Pressure Range	10-125 psi (0.7 -8.6 bar)
Inlet Water Temperature Range	35° -100° F (2° -38° C)
Shipping Weight	3 lbs.
Performance	
Chlorine, Taste and Odor Reduction Capacity	20,000 gals. (75,700 liters)
Service Flow Rate	2.0 gpm (7.6 lpm)
Sediment Reduction	5 micron (nominal)
Scale & Corrosion Inhibitor	IsoNet (70 grams)

► Replacement Cartridge(s)

Model	Part Number	Qty
PTS-Q	300-05805	1

It is recommended that filters be changed every six months, when capacity is reached or when effluent pressure or flow becomes inadequate.

This product is for commercial use only and must be installed and maintained according to manufacturers guidelines.

Do not use on water that is microbiologically unsafe or of unknown quality without adequate disinfection before or after the system.

► Warranty

Systems have a 3 year warranty against defects in material and workmanship. Contact OptiPure customer service or go to the OptiPure website for a copy of the warranty.

OptiPure, Mfg. by Procam Controls, Inc.
2605 Technology Dr., Bldg 300
Plano, TX 75074
p: 972.881.9797; f: 972.422.6262
www.optipurewater.com